



SLV Series
VERTICAL TURNING CENTER



SMEC Co., Ltd.
157-10, Goldenroot-ro, Juchon-myeon, Gimhae-si,
Gyeongsangnam-do, Korea
Tel +82 55 340 4800 / Fax +82 55 340 4740
www.esmec.com



SLV Series
| SLV 500/M
| SLV 800/M
| SLV 1000/M



SLV Series

SLV 500/800/1000/M

High Rigidity, High Precision Vertical Turning Center Designed to Provide Both Heavy Duty and High Precision Machining

- Superb structural design supporting both best-in-class heavy duty and precision machining
- High precision heavy duty cutting is ensured by the box guideways and thermal growth minimizing structural design
- The large screen OP Panel enhances operator ease of use
- The high-speed indexing turret significantly reduces non-cutting time while increasing productivity

[]: Option

Category		SLV 500/M	SLV 800/M	SLV 1000/M
Chuck size	inch	12" 15"	18"[15] 21" 24"	24" 32"
Swing over bed	mm	700	890	1,100
Max turning length	mm	495	800	955
Spindle bore	mm	60	104	100
Main spindle speed	rpm	3,000 2,000	2,000 1,800 1,500	1,800 800
Travels (X/Z)	mm	317/495	440/800	540/955
Rapid traverse (X/Z)	m/min	20/20	20/20	20/20
Motor (cont./max) [Gearbox]	kW	18.5/26	22/30[30/37]	37/55

Extensive machining capacity lineup

The extensive lineup of up to a maximum Ø1,000mm turning diameter and 32-inch chuck ensures customer satisfaction

High rigidity bed and column design

The bed and column are made of Meehanite to minimize thermal growth and the ribbed design provides excellent vibration dampening. The low friction box way design supports high precision and heavy duty cutting

Effective chip discharge design

The large capacity flushing system minimizes chip build-up and the steeply sloped bed design ensures effective chip discharge.

Ease of use

Ease of use is enhanced with the OP Panel's large 15" LCD screen and easy to maintain coolant tank.

SLV Series

VERTICAL TURNING CENTER

Extensive machining capacity lineup

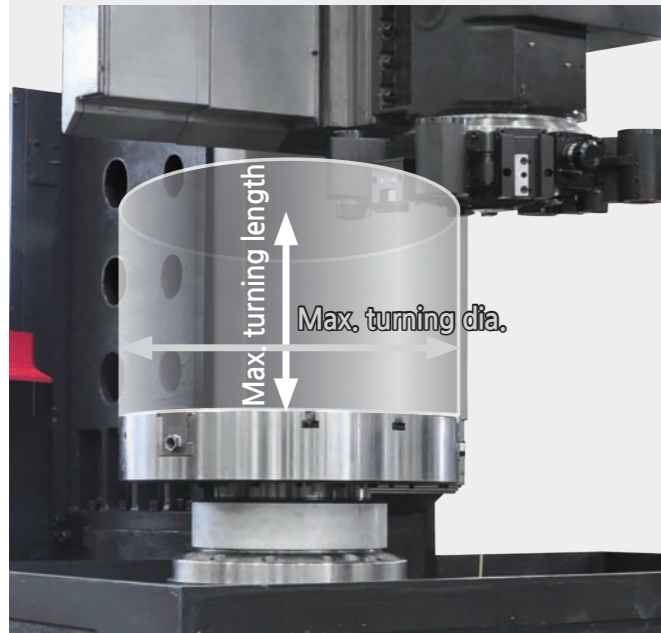

The SLV Series offers an extensive lineup up to a maximum Ø1,000mm turning diameter and 32-inch chuck.

SLV 500/M

Max turning dia./length
Ø500/495mm

SLV 800/M

Max turning dia./length
Ø830/800mm

SLV 1000/M

Max turning dia./length
Ø1000/955mm

Model	Unit	Swing over bed	Max turning dia.	Max turning length
SLV 500/M	mm	Ø700	Ø500	495
SLV 800/M	mm	Ø890	Ø830	800
SLV 1000/M	mm	Ø1,100	Ø1,000	955

High rigidity bed and column design

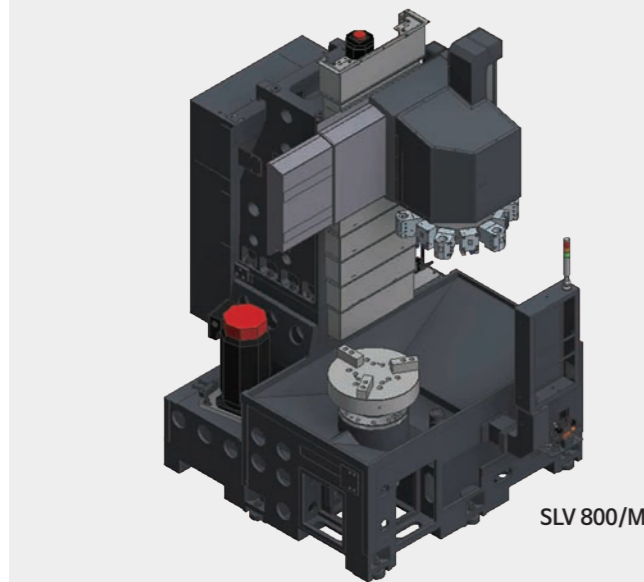

All travel axes are comprised of high rigidity box guideways enabling heavy duty cutting and superb productivity

The set of 3 gibs for each axis allows for safe operation without loss of cutting precision and provides easier maintenance.



Model	Main chuck size	Travel (mm)		Rapid traverse (m/min)	
		X-axis	Z-axis	X-axis	Z-axis
SLV 500/M	12/15	317	495	20	20
SLV 800/M	18/21/24"	440	800	20	20
SLV 1000/M	24/32"	540	955	20	20

Effective chip discharge design



Convenient chip discharge
Large capacity coolant flushing system

The large capacity flushing system minimizes chip build-up and the steeply sloped bed design ensures effective chip discharge.

Discharge capacity :
165 L/min(SLV 500/M, SLV 800/M)
220 L/min(SLV 1000/M)

Ease of use

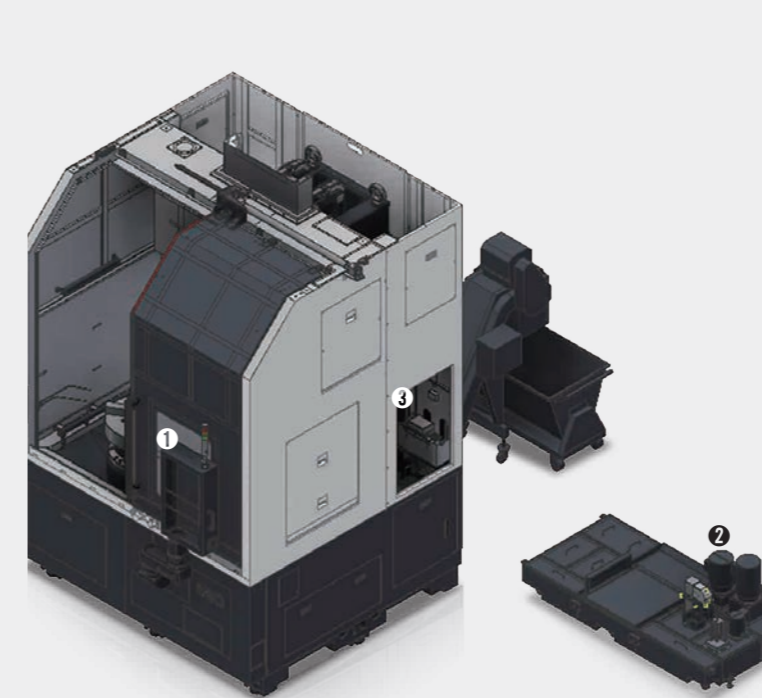

1 User-centric Large 15" OP Panel

The QWERTY-type keyboard and high visibility buttons and effective button placement enhances ease of use

2 Easy coolant tank maintenance

When cleaning the coolant tank, the coolant tank may be removed while leaving the chip conveyor attached to the machine, making it easier to clean and maintain

3 Highly reliable lubrication distribution system

The highly reliable lubrication pump supplies the correct amount of oil to every guideway via metering valves.

SLV Series

VERTICAL TURNING CENTER

Turret

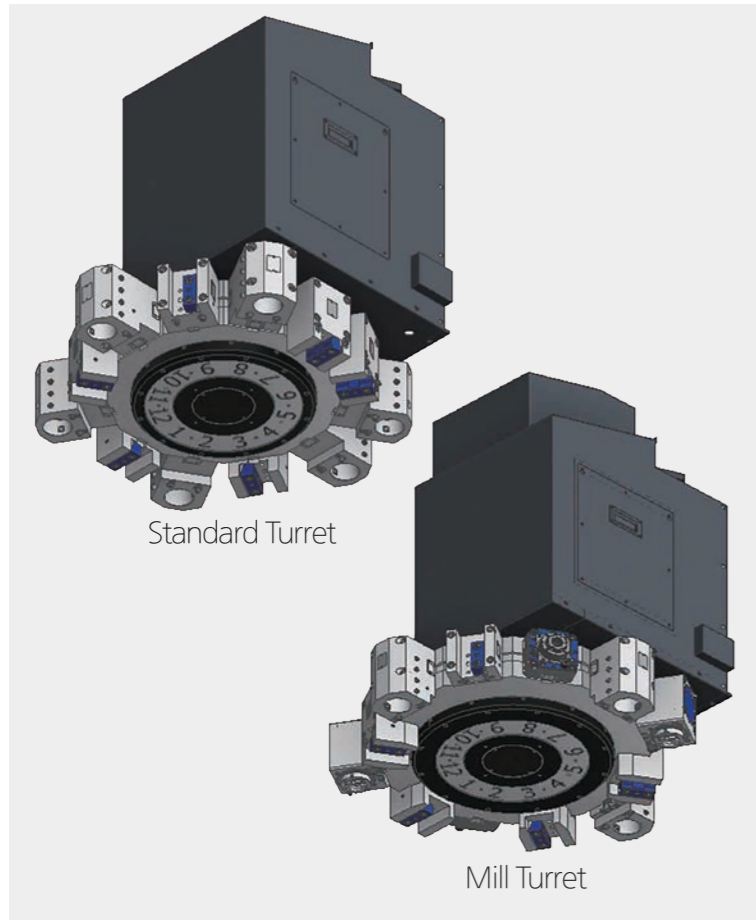

Servo Turret

Turret indexing times of 0.18 and 0.3 seconds per station are achieved with Non-stop Random Indexing using High-power Servo Index Motors. While the large diameter curvic couplings significantly increases clamping power and indexing precision.

The SLV 500M (BMT65) / SLV 800M (BMT75) / SLV 1000M (BMT 85) comes standard with 12 station turrets that can accept a rotary tool in every tool position.

Turret index time :

0.18sec(SLV 500/M)

0.3sec(SLV 800/M, 1000/M)

No. of tool positions : **12**EA

Spindle



Main Spindle Structure

The high-torque spindle is supported by strong Double Cylinder Roller bearings and Angular Thrust bearings enabling heavy-duty turning and minimized spindle acceleration/deceleration times.

Category	SLV 500/M	SLV 800/M	SLV 1000/M
Drive method	Belt	Belt/Gear	Gear
Max speed (RPM)	3,000	2,000	1,800
Max power (kW)	26	30	55
Max torque (N.m)	864	1,158	5,026
Spindle nose (ASA)	A2-8	A2-11	A2-15
Bearing I.D. (mm)	Ø130	Ø160	Ø200

Accessories[Optional]

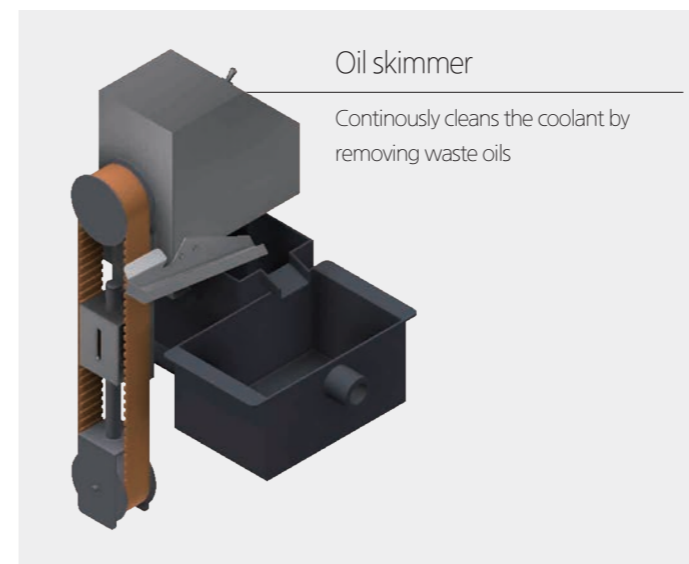

Oil skimmer

Continuously cleans the coolant by removing waste oils



Autodoor

Used to quickly open/close the operator door via program to increase productivity in an automation line.

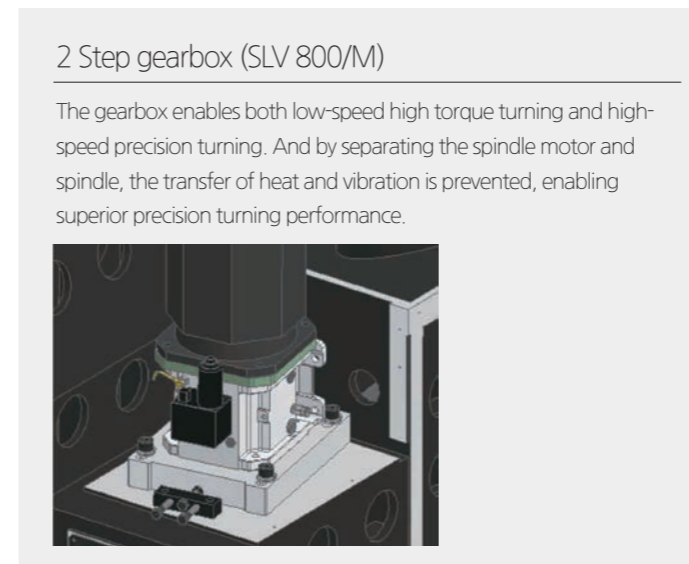

2 Step gearbox (SLV 800/M)

The gearbox enables both low-speed high torque turning and high-speed precision turning. And by separating the spindle motor and spindle, the transfer of heat and vibration is prevented, enabling superior precision turning performance.

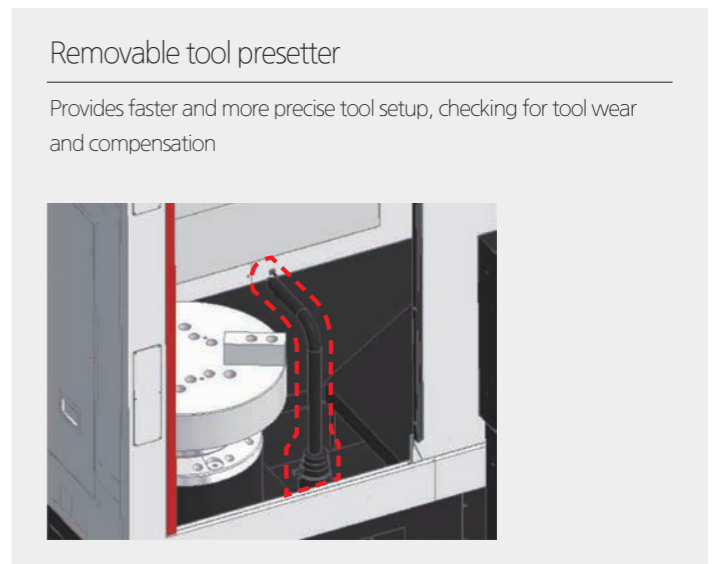

Removable tool presetter

Provides faster and more precise tool setup, checking for tool wear and compensation



Servo tailstock (SLV 500/M)

The servo tailstock supports high-speed, high-precision turning, while reducing cycle time and increasing productivity

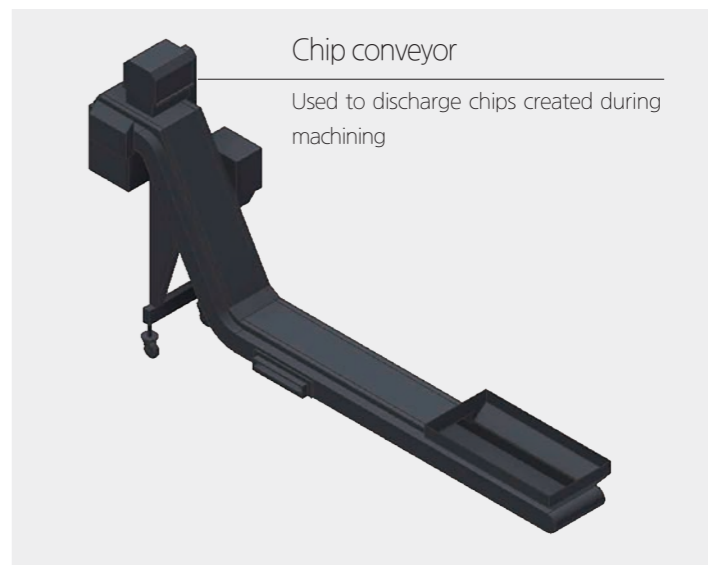

Chip conveyor

Used to discharge chips created during machining

Power-Torque Diagram

SLV 500/M Chuck : 12"

Max speed 3,000rpm Power (cont/max) 18.5/26kW Torque (cont/max) 614.7/863.9N·m

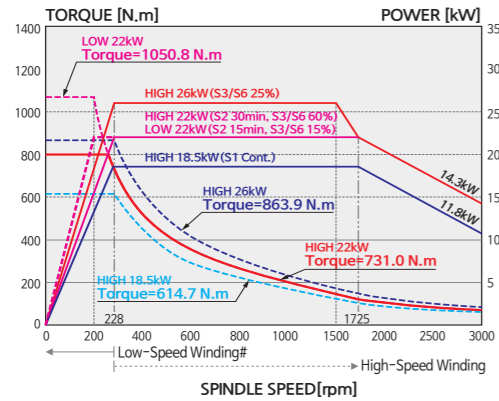

SLV 800/M Chuck : 18"

Max speed 2,000rpm Power (cont/max) 22/30kW Torque (cont/max) 850/1,158N·m

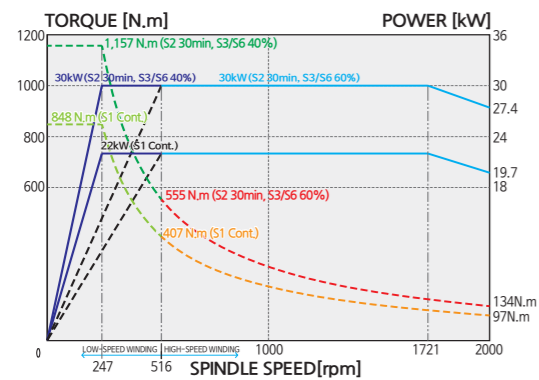

SLV 1000/M Chuck : 24"

Max speed 1,800rpm Power (cont/max) 37/55kW Torque (cont/max) 614.7/5,026N·m

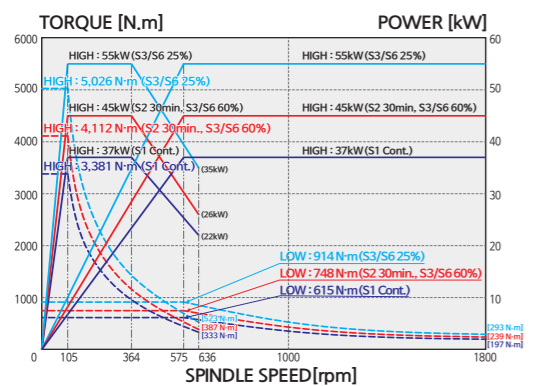

SLV 500M_MILL Motor

Max speed 5,000rpm Power (cont/max) 3.7/5.5kW Torque (cont/max) 17.7/35N·m

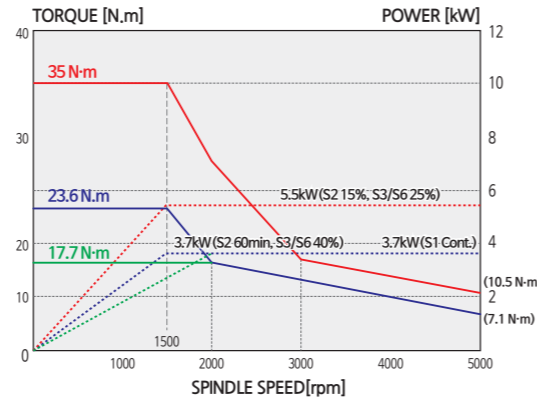

SLV 800M_MILL Motor

Max speed 4,000rpm Power (cont/max) 5.5/11kW Torque (cont/max) 35/70.1N·m

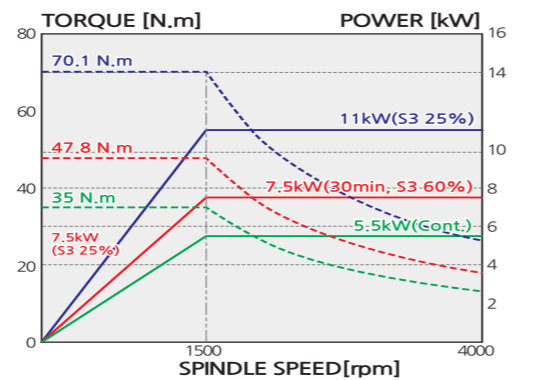

SLV 1000M_MILL Motor

Max speed 3,000rpm Power (cont/max) 5.5/11kW Torque (cont/max) 70/140N·m

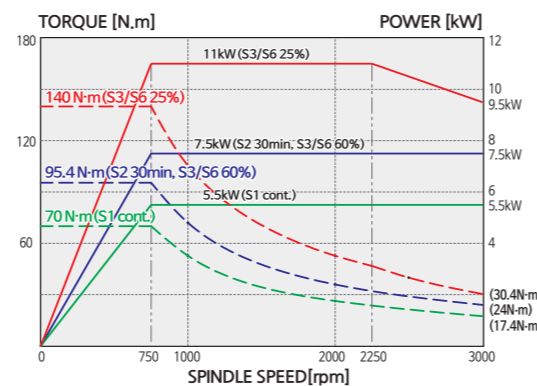

Cutting Performance

Test conditions : SLV 500(12")

O.D Cutting

Cutting dia.	mm	Ø162
Cutting depth	mm	6.0
Cutting speed	m/min	172
Spindle speed	rpm	491
Feedrate	mm/rev	0.35
Chip removal rate	cc/min	525

U-Drill Cutting

U-drill dia.	mm	Ø60
Cutting speed	m/min	113
Spindle speed	rpm	599
Feedrate	mm/rev	0.13
Chip removal rate	cc/min	588

Tap

Tap size	mm	M20×2.5
Cutting depth	mm	30
Cutting speed	m/min	10
Spindle speed	rpm	159
Feedrate	mm/rev	2.5

Endmill

Endmill dia.	mm	Ø20
Cutting depth	mm	7
Cutting speed	m/min	95
Spindle speed	rpm	1,512
Feedrate	mm/min	726
Chip removal rate	cc/min	102

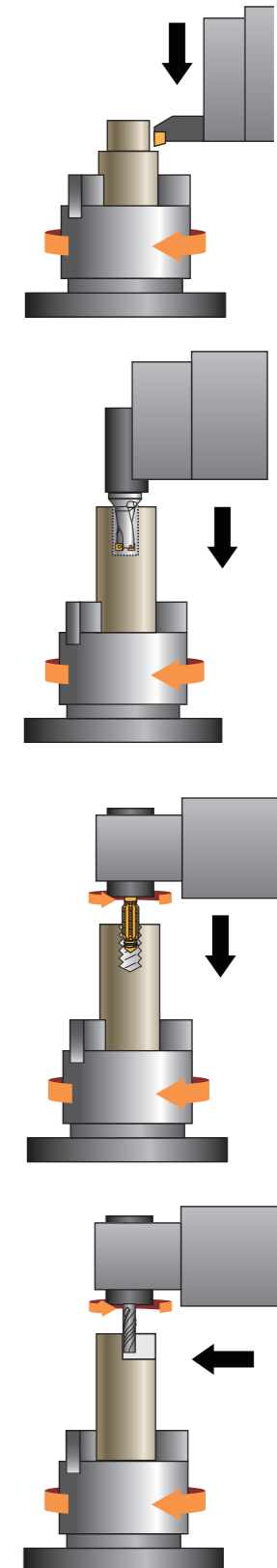

※ The above data is based on internal testing. Values may change depending on cutting conditions.

SMC FANUC i series



- 15" LCD color display
- High quality designed OP Panel
- Conversational programming, Manual Guide i
- Part program size 2MB
- SMC Custom S/W

SMC Custom S/W displayed using MDI's **S1** button or OP Panel's **CUSTOM** button

CUSTOM : Provide operator convenience and improve productivity using the support function for tool management and additional device setting.



M/G-Code check function

Allows the operator to directly read the M/G-Code on the machine for easy application programming



Easy tailstock setting

Easily configure a variety of functions such as travel limiting, origin setting and signal check

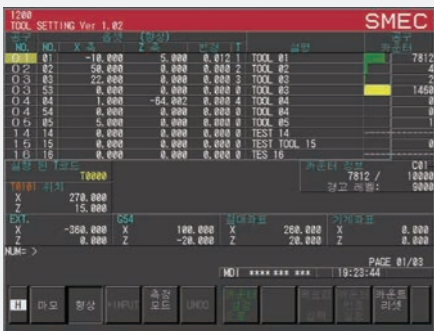

Display only the necessary tools and offsets and check the configured counter at the same time

Tool information and setting management mode



PMc alarm check function

When a PMc alarm occurs, the cause and countermeasures are described in detail, making operation and maintenance more convenient



Counter for each T-Code

Manual Guide i (STD)

SMC's Manual Guide i system enables advanced part program creation and more efficient and faster machining with conversational programming



Check cutting result using cutting simulation



Check cutting path using cutting simulation

Easy program creation and editing

Program creation using advanced part program editing and extensive cutting cycles

Check program using cutting simulations

Program pre-check using realistic cutting simulation

Effective cutting setup

Tool and cutting condition offset data setup based on measurement cycle

Advanced cutting capabilities

Check cutting status such as cutting cycle name and tool icon during the cutting process

Measurement

Feedback of cutting results and tool offset values after cutting

IoT Solution (OPT)



NC-Gate / IoT-Gate

The NC-Gate / IoT-Gate that was developed in-house with our ICT technology is a universal gateway that not only interworks with our machine tools, but machine tools from other manufacturers, robots, automation equipment, and analog / digital sensors as a network device capable of bi-directional communication.

Supported drivers : Fanuc / Mitsubishi / Siemens NC, Modbus TCP, DeviceNet, Profibus, Ethernet, AI/DI/DO



Provides key performance indicators and displays target achievement

Indicators : achievement rate, productivity, process defect rate, equipment and factory usage, quality defect rate, lead time, and average cycle time



Provides figures and graphs of overall equipment effectiveness

Availability, performance, quality, etc.



Provides operation status and alarm information in case of problems in the production line

Provides information about the operation status, speed, production alarms, etc. of each machine



Remote control and operation

Emergency stop switch, program editing, etc.

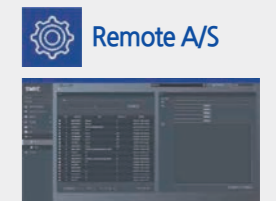

Problem diagnosis via remote control

Provide remote diagnosis services to users via the IIoT solution

Machine Dimensions

Unit : mm

Top view

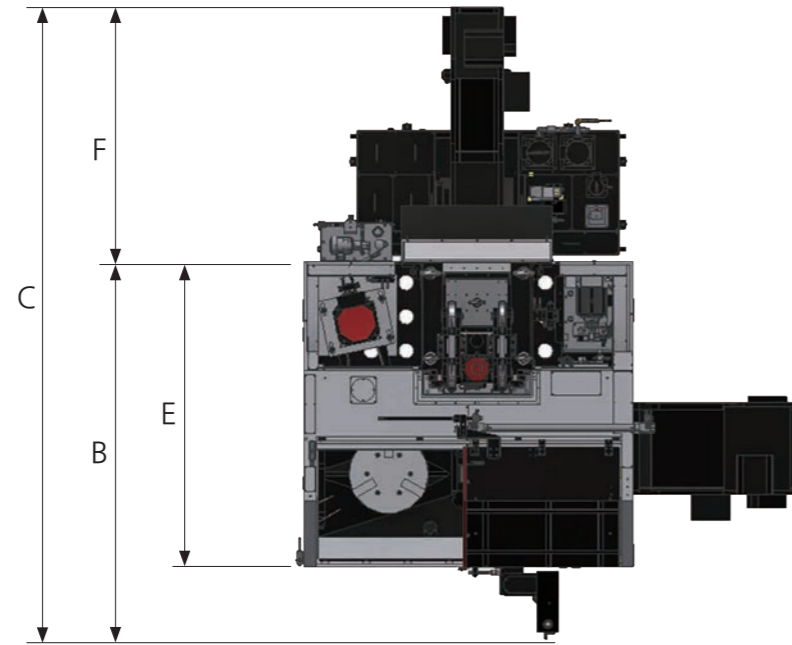

Front view

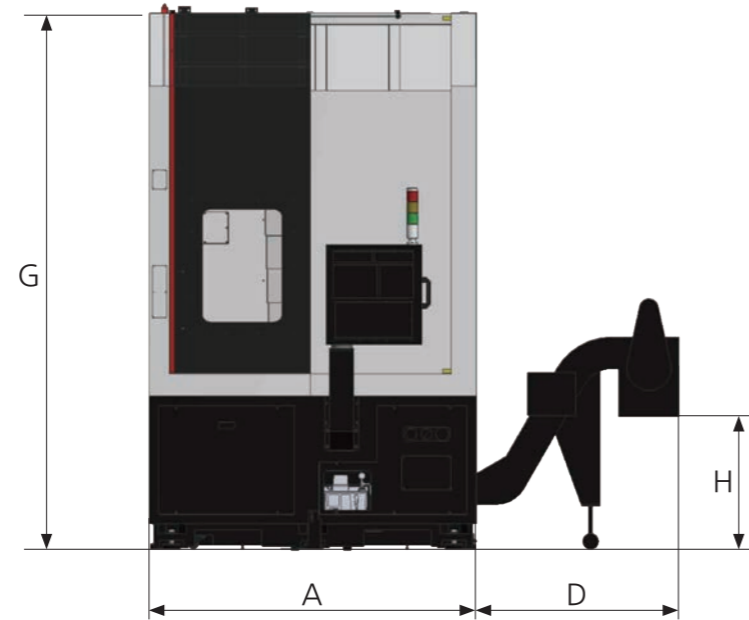

Model	A (Machine front)	B	C	D	E (Machine side)	F	G (Machine side)	H
SLV 500/M	1,670	2,527	4,331	1,111	1,798	1,803	2,774	1,068
SLV 800/M	2,052	2,697	4,632	1,287	2,115	1,935	3,352	994
SLV 1000/M	2,510	3,155	5,089	1,234	2,328	1,933	3,619	1,076

Turret Interference

Unit : mm

SLV 500

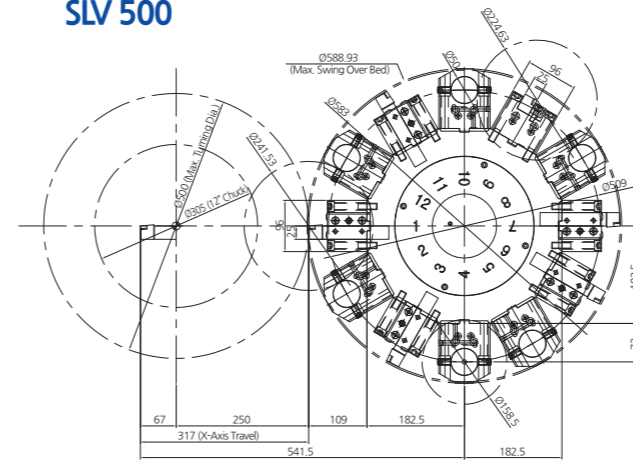

SLV 500M

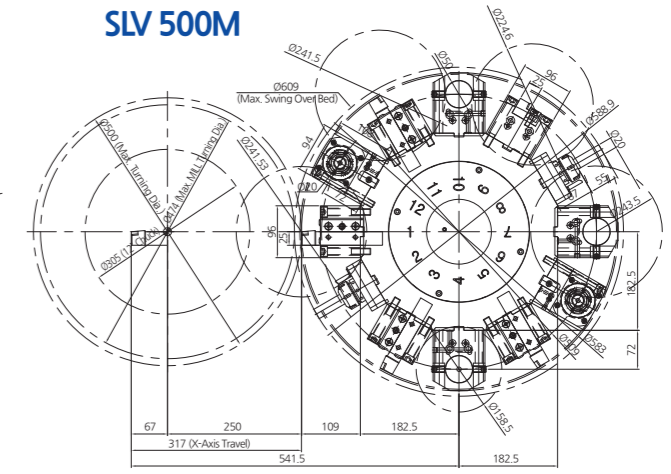

SLV 800

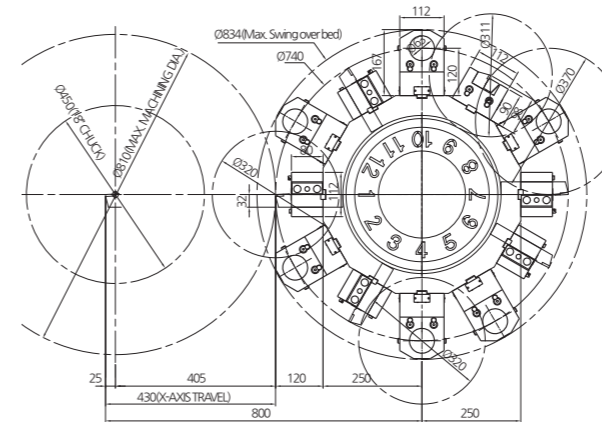

SLV 800M

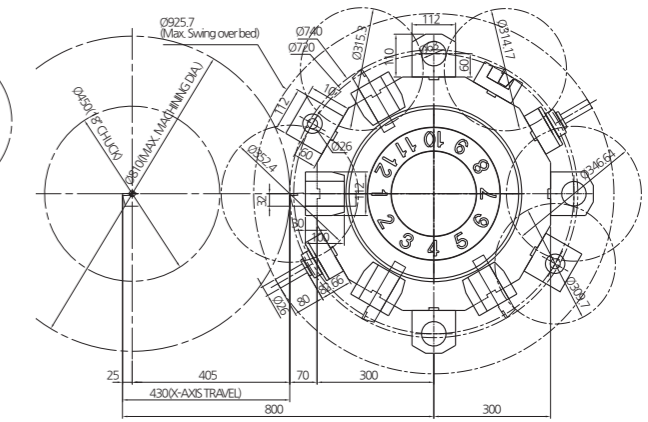

SLV 1000

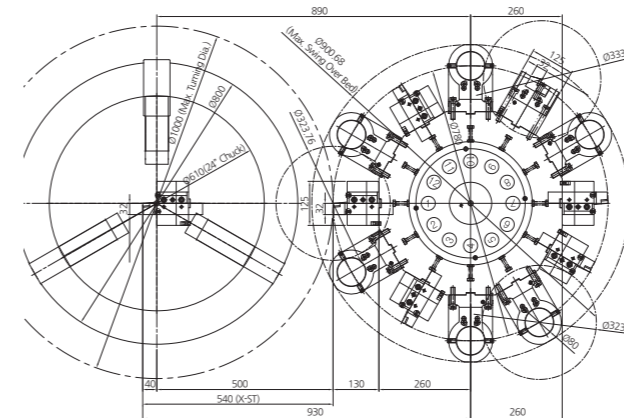

SLV 1000M

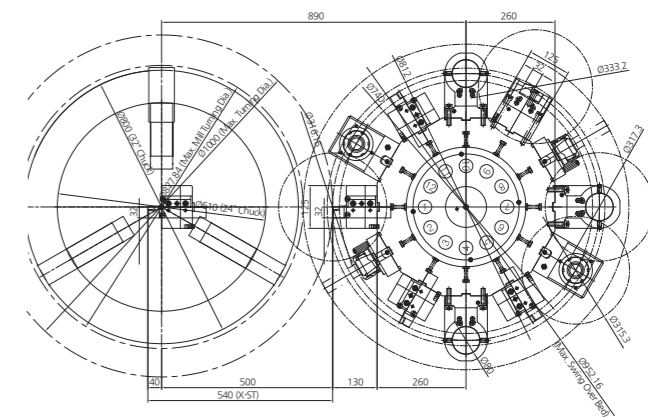

Work Range

SLV 500/M

Unit : mm

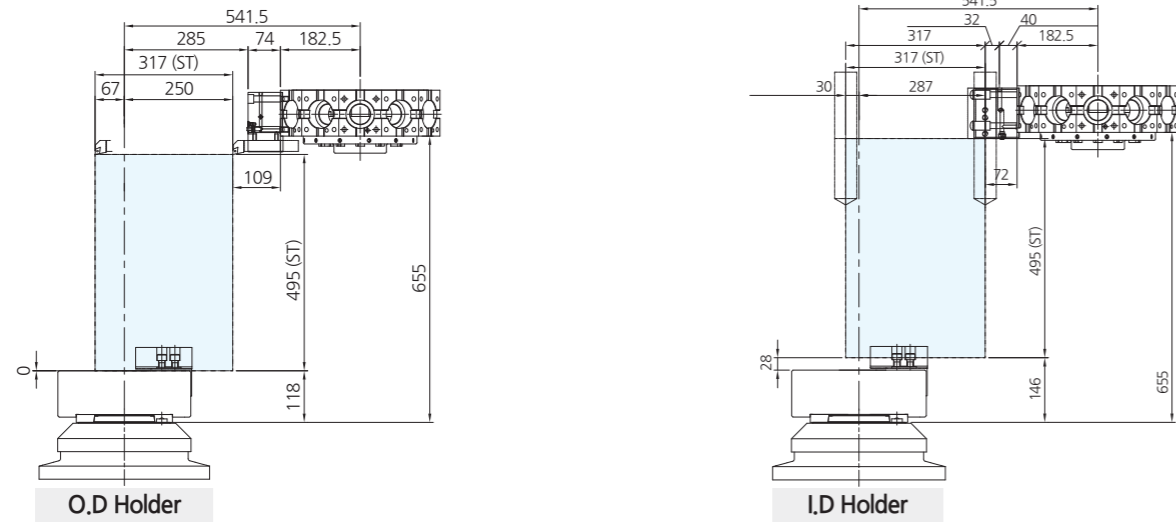

O.D Holder

I.D Holder

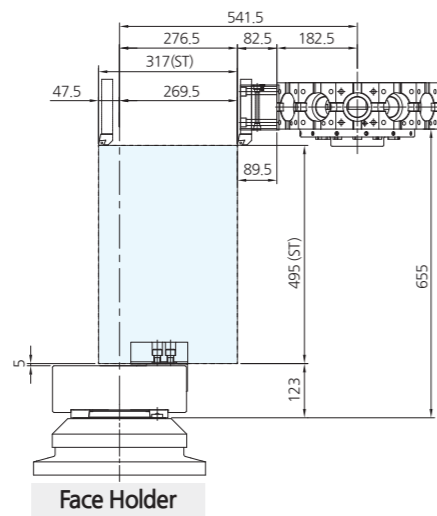

Face Holder

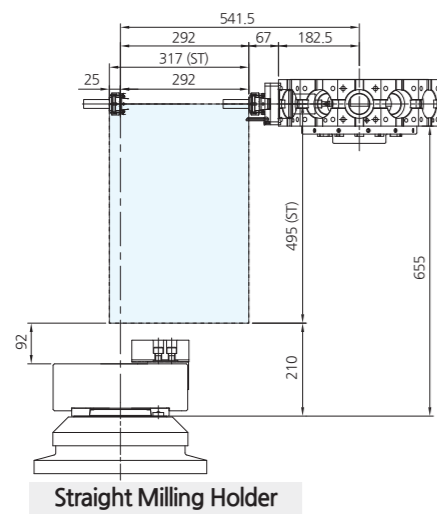

Straight Milling Holder

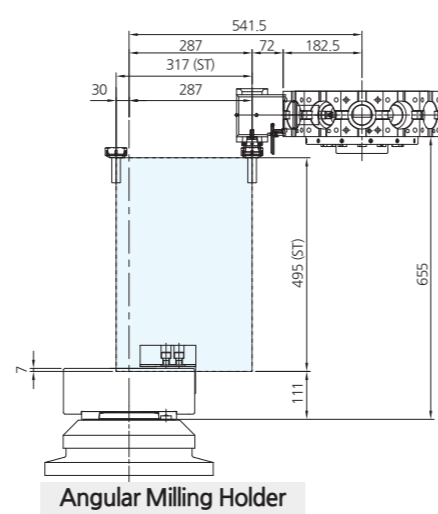

Angular Milling Holder

Work Range

SLV 800/M

Unit : mm

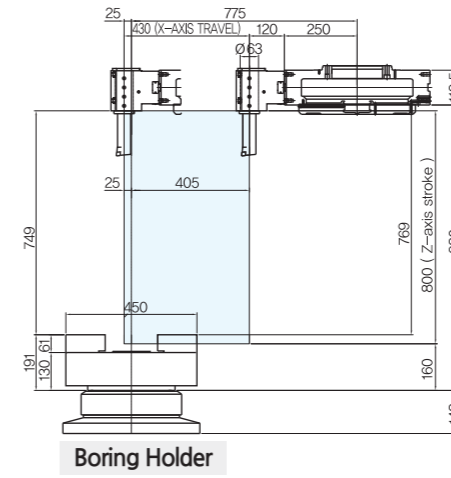

Boring Holder

SLV 800

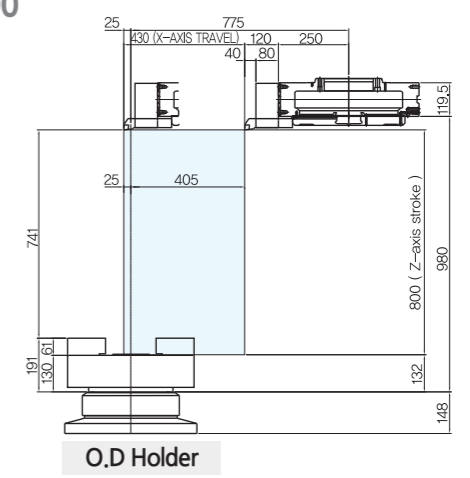

O.D Holder

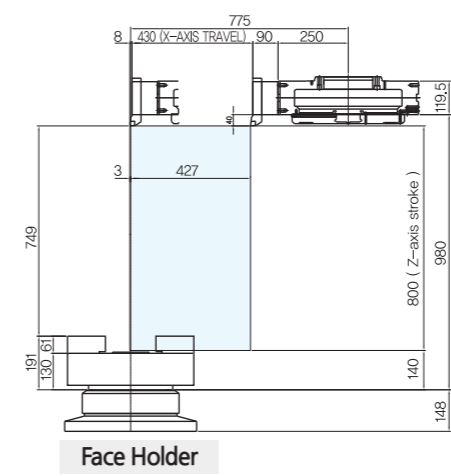

Face Holder

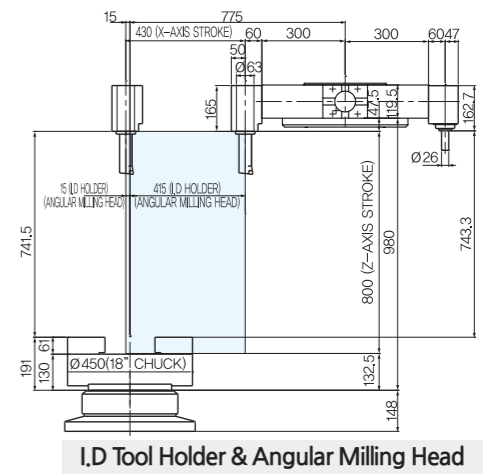

I.D Tool Holder & Angular Milling Head

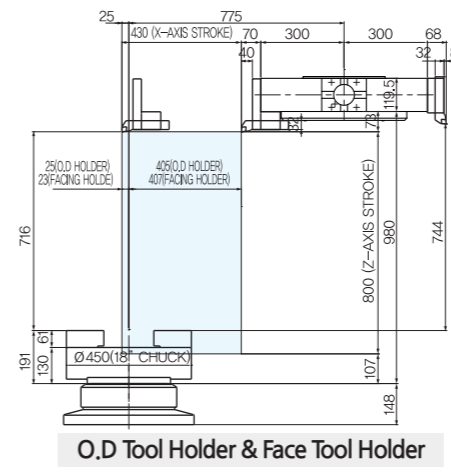

O.D Tool Holder & Face Tool Holder

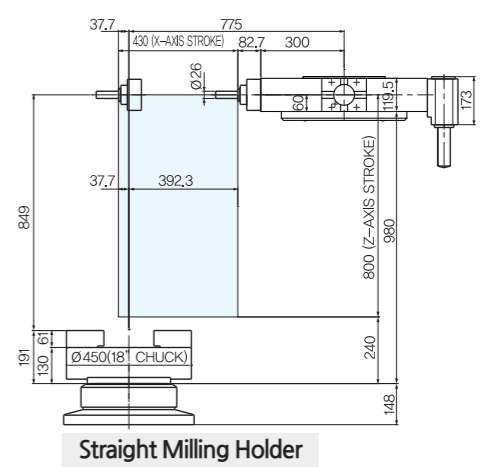

Straight Milling Holder

SLV 800M

Work Range

SLV 1000/M

Unit : mm

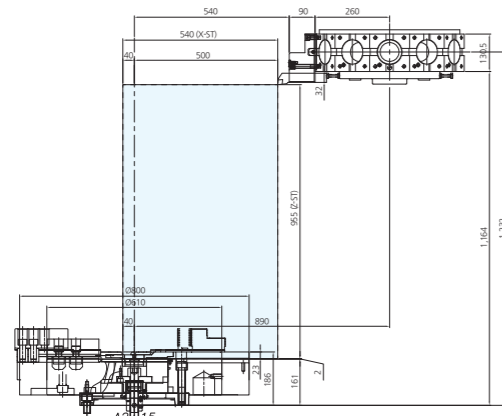

O.D Holder

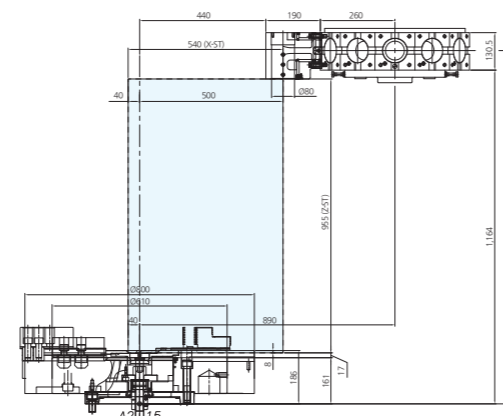

I.D Holder

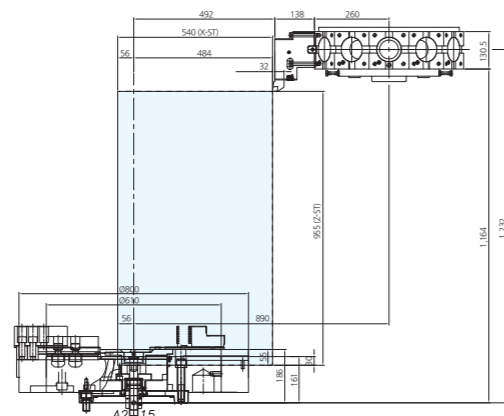

Face Holder

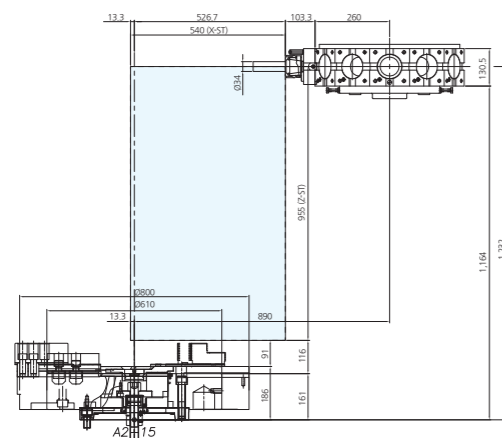

Straight Milling Holder

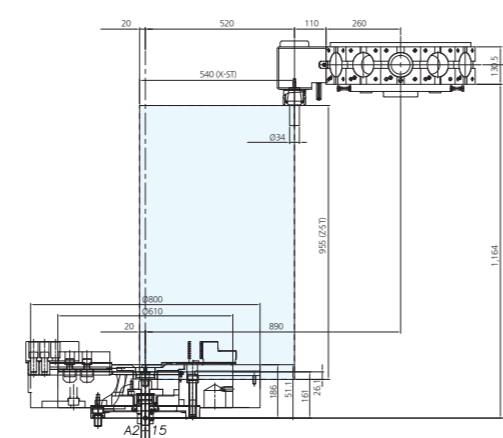

Angular Milling Holder

Tooling System

Unit : mm

SLV 500/M
SLV 800/M
SLV 1000/M

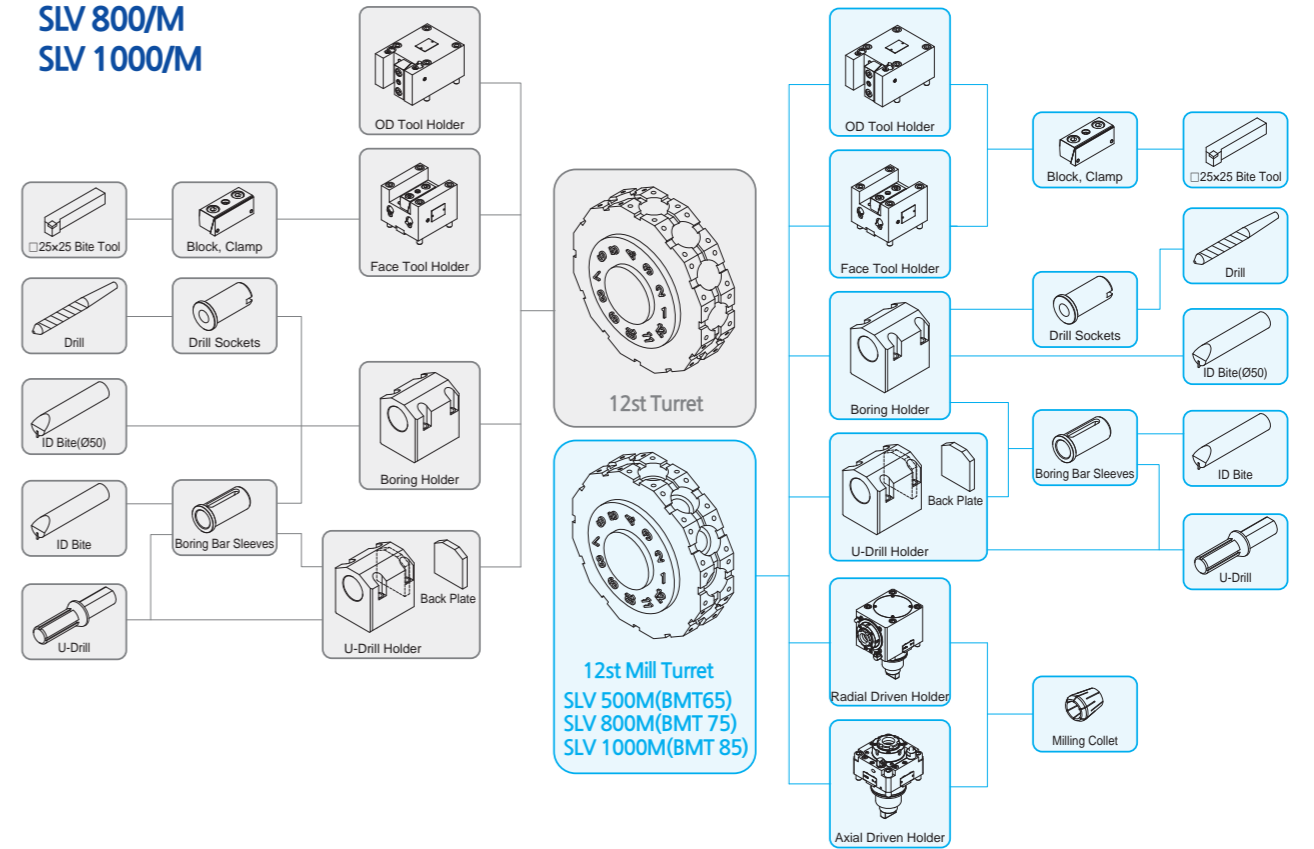

Standard Tooling

Item / Description		SLV 500	SLV 800	SLV 1000	SLV 500M	SLV 800M	SLV 1000M	
Static Holder	OD Holder	5	5	5	4	4	4	
	Face Holder	1	1	1	1	1	1	
Boring Holder	ID Holder	5	5	5	2	2	2	
	U-Drill Holder	1	1	1	1	1	1	
Milling Holder	Axial Milling Holder	-	-	-	2	2	2	
	Radial Milling Holder	-	-	-	2	2	2	
Socket	Boring	Ø10	1	1	1	1	1	
		Ø12	1	1	1	1	1	
		Ø16	1	1	1	1	1	
		Ø20	1	1	1	1	1	
		Ø25	1	1	1	1	1	
		Ø32	1	1	1	1	1	
		Ø40	1	1	1	1	1	
	Drilling	MT3	1	1	1	1	1	1
		MT4	1	1	1	1	1	1
		MT5	-	1	1	-	1	1
ER Collet				1	1	1		

SLV Series

VERTICAL TURNING CENTER

Standard / Optional

● : Standard ○ : Optional △ : Discuss X : N/A

Category		SLV 500	SLV 500M	SLV 800	SLV 800M	SLV 1000	SLV 1000M	
Spindle	3 jaw open-center chuck	X	X	X	X	X	X	
	3 jaw closed-center chuck	●	●	●	●	●	●	
	Soft jaw (3set)	●	●	●	●	●	●	
	Hard jaw (1set)	○	○	○	○	○	○	
	Chuck clamp footswitch	●	●	●	●	●	●	
	Dual pressure chucking	○	○	○	○	○	○	
	C-axis control (0.001°)	○	●	○	●	○	●	
	Chuck clamp confirmation	●	●	●	●	●	●	
	Chuck dual footswitch	○	○	○	○	○	○	
	2 step gearbox	X	X	○	○	●	●	
Turret	Tool holder	●	●	●	●	●	●	
	Rotary holder type	BMT	●	●	●	●	●	
	Rotary holder (axial)	Collet-type, 2EA	X	●	X	●	X	●
	Rotary holder (radial)	Collet-type, 2EA	X	●	X	●	X	●
	Boring bar sleeve (same as U-drill holder sleeve)	●	●	●	●	●	●	
	Drill socket	●	●	●	●	●	●	
	U-drill holder	●	●	●	●	●	●	
	Swivel head holder	X	X	X	X	X	X	
Tailstock	NC(Servo Motor) tailstock	○	○	X	X	X	X	
	Live center (standard with tailstock)	○	○	X	X	X	X	
	High precision live center	△	△	X	X	X	X	
	Tailstock 2 step pressure system	○	○	X	X	X	X	
	Quill forward/reverse confirmation	○	○	X	X	X	X	
Tailstock footswitch	○	○	X	X	X	X		
Coolant & Air Blow	Standard coolant (nozzle)	●	●	●	●	●	●	
	Coolant above chuck	○	○	○	○	○	○	
	Coolant gun	○	○	○	○	○	○	
	TSC for chuck (for special chuck)	X	X	X	X	X	X	
	Bed flushing	●	●	●	●	●	●	
	Air blower	○	○	○	○	○	○	
	Rotary tool holder TSC	X	X	X	X	X	X	
	Tailstock air blower	△	△	X	X	X	X	
	Turret tool air blower	X	X	X	X	X	X	
	Air gun	○	○	○	○	○	○	
	Through spindle air blower (for special chuck)	△	△	△	△	△	△	
	Coolant pump	4.5Bar	●	●	●	●	●	●
		7Bar	○	○	○	○	○	○
		10Bar	○	○	○	○	○	○
		14.5Bar	○	○	○	○	○	○
20Bar		○	○	○	○	○	○	
Power coolant system (for automation solutions)	△	△	△	△	△	△		
Coolant chiller	△	△	△	△	△	△		
Chip Disposal	Coolant tank	●	●	●	●	●	●	
	Chip conveyor (Hinge / Scraper)	Side	○	○	○	○	○	○
		Rear	●	●	●	●	●	●
	Special chip conveyor (drum filter)	△	△	△	△	△	△	
Chip bucket	Fixed 380L	○	○	○	○	○	○	

※ For detailed information, please contact your local SMEC dealer.

Standard / Optional

● : Standard ○ : Optional △ : Discuss X : N/A

Category		SLV 500	SLV 500M	SLV 800	SLV 800M	SLV 1000	SLV 1000M	
Safety Features	Door interlock	●	●	●	●	●	●	
	Backspin torque limiter(BST)	△	△	△	△	△	△	
	Torque limiter	△	△	△	△	△	△	
	Full splash guard	●	●	●	●	●	●	
	Chuck hyd pressure interlock	△	△	△	△	△	△	
Electrical	3 step patrol lamp and buzzer	○	○	○	○	○	○	
	Lamp for electrical cabinet	○	○	○	○	○	○	
	Remote MPG	○	○	○	○	○	○	
	Work counter	Digital	○	○	○	○	○	○
	Total counter	Digital	○	○	○	○	○	○
	Tool counter	Digital	○	○	○	○	○	○
	Multi counter	6개	○	○	○	○	○	○
		9개	○	○	○	○	○	○
	Grounded circuit breaker	○	○	○	○	○	○	
	AVR(Auto Voltage Regulator)	○	○	○	○	○	○	
	Transformer	25kVA	○	○	○	○	○	○
		30kVA	○	○	○	○	○	○
Auto Power Off	○	○	○	○	○	○		
Measurement	Tool Presetter	Manual	X	X	X	X	X	
		Auto	X	X	X	X	X	
		Removable	○	○	○	○	○	○
	Air zero measuring device (for special chuck)	TACO	△	△	△	△	△	△
		SMC	△	△	△	△	△	△
Linear scale	X-axis	○	○	○	○	○	○	
	Z-axis	○	○	○	○	○	○	
Coolant level gauge (requires chip conveyor)	○	○	○	○	○	○		
Environmental	Air conditioner for electrical cabinet	○	○	○	○	○	○	
	Dehumidifier	○	○	○	○	○	○	
	Oil mist collector	○	○	○	○	○	○	
	Oil skimmer	○	○	○	○	○	○	
	MQL(Minimal Quantity Lubrication)	X	X	X	X	X	X	
Automation	Auto door	○	○	○	○	○	○	
	Auto shutter (for automation solutions)	X	X	X	X	X	X	
	Sub controller	○	○	○	○	○	○	
	Barfeeder interface	X	X	X	X	X	X	
	Additional M-codes (4 pairs)	○	○	○	○	○	○	
	Automation interface	○	○	○	○	○	○	
	I/O expansion (including both IN and OUT)	16 contacts	○	○	○	○	○	○
32 contacts		○	○	○	○	○	○	
Hydraulic Supply	Standard hydraulic cylinder	Closed-center	●	●	●	●	●	
	Standard hydraulic unit	35Bar	●	●	X	X	X	X
50Bar		X	X	●	●	●	●	

※ For detailed information, please contact your local SMEC dealer.

SLV Series

VERTICAL TURNING CENTER

Machine Specifications

[]: Option

Category			SLV 500		SLV 500M	
			A type	B type	A type	B type
Chuck	Chuck size	inch	12"	15"	12"	15"
Capacity	Swing over bed	mm	700	700	700	700
	Swing over cross-slide (with tailstock)	mm	400(360)	400(360)	400(360)	400(360)
	Max turning diameter	mm	500	500	500	500
	Max milling diameter	mm	-	-	474	474
	Max turning length	mm	495	495	495	495
Spindle	Spindle speed	rpm	3,000	2,000	3,000	2,000
	Spindle nose	ASA	A2-8	A2-8	A2-8	A2-8
	Draw tube ID	mm	-	-	-	-
	Spindle bore	mm	60	60	60	60
	Spindle motor (cont/max)	kW	18.5/26	18.5/26	18.5/26	18.5/26
Travels	X-axis stroke	mm	317	317	317	317
	Z-axis stroke	mm	495	495	495	495
	X-axis stroke	m/min	20	20	20	20
	Z-axis stroke	m/min	20	20	20	20
Turret	No of tool positions	ea	12	12	12(BMT65)	12(BMT65)
	OD tool size	mm	25	25	25	25
	Boring bar diameter	mm	50	50	50	50
	Indexing time	sec	0.18	0.18	0.18	0.18
	Rotary tool speed	rpm	-	-	5,000	5,000
	Rotary tool motor (cont/max)	kW	-	-	3.7/5.5	3.7/5.5
Tailstock	Quill diameter	mm	[110]	[110]	[110]	[110]
	Quill stroke	mm	[450]	[450]	[450]	[450]
	Quill taper	MT	[MT5]	[MT5]	[MT5]	[MT5]
Machine	Size (with SIDE chip conveyor) L×W×H	mm	1,670(2,782) × 1,798 × 2,774		1,670(2,782) × 1,798 × 2,774	
	Size (with REAR chip conveyor) L×W×H	mm	1,670 × 1,798(3,602) × 2,774		1,670 × 1,798(3,602) × 2,774	
	Weight	kg	7,100	7,100	7,200	7,200
	Coolant tank capacity	Liter	250		250	
Electric power supply	kVA/V	40/220	40/220	45/220	45/220	
Controller	FANUC					

* Design and specifications are subject to change without notice.

Machine Specifications

Category			SLV 800			SLV 800M		
			A type	B type	C type	A type	B type	C type
Chuck	Chuck size	inch	18[15]"	21"	24"	18[15]"	21"	24"
Capacity	Swing over bed	mm	890	890	890	890	890	890
	Swing over cross-slide (with tailstock)	mm	740	740	740	740	740	740
	Max turning diameter	mm	830	830	830	830	830	830
	Max milling diameter	mm	-	-	-	624	624	624
	Max turning length	mm	800	800	800	800	800	800
Spindle	Spindle speed	rpm	2,000	1,800	1,500	2,000	1,800	1,500
	Spindle nose	ASA	A2-11	A2-11	A2-11	A2-11	A2-11	A2-11
	Draw tube ID	mm	-	-	-	-	-	-
	Spindle bore	mm	104	104	104	104	104	104
	Spindle motor (cont/max)	kW	22/30[30/37]	22/30[30/37]	22/30[30/37]	22/30[30/37]	22/30[30/37]	22/30[30/37]
Travels	X-axis stroke	mm	440	440	440	440	440	440
	Z-axis stroke	mm	800	800	800	800	800	800
	X-axis stroke	m/min	20	20	20	20	20	20
	Z-axis stroke	m/min	20	20	20	20	20	20
Turret	No of tool positions	ea	12	12	12	12(BMT75)	12(BMT75)	12(BMT75)
	OD tool size	mm	32	32	32	32	32	32
	Boring bar diameter	mm	63	63	63	63	63	63
	Indexing time	sec	0.30	0.30	0.30	0.30	0.30	0.30
	Rotary tool speed	rpm	-	-	-	4,000	4,000	4,000
	Rotary tool motor (cont/max)	kW	-	-	-	5.5/11	5.5/11	5.5/11
Tailstock	Quill diameter	mm	-	-	-	-	-	-
	Quill stroke	mm	-	-	-	-	-	-
	Quill taper	MT	-	-	-	-	-	-
Machine	Size (with SIDE chip conveyor) L×W×H	mm	2,052(3,340) × 2,115 × 3,352			2,052(3,340) × 2,115 × 3,352		
	Size (with REAR chip conveyor) L×W×H	mm	2,052 × 2,115(4,051) × 3,352			2,052 × 2,115(4,051) × 3,352		
	Weight	kg	11,000	11,000	11,000	11,200	11,200	11,200
	Coolant tank capacity	Liter	300			300		
Electric power supply	kVA/V	53/220	53/220	53/220	61/220	61/220	61/220	
Controller	FANUC							

* Design and specifications are subject to change without notice.

SLV Series

VERTICAL TURNING CENTER

Machine Specifications

Category		SLV 1000		SLV 1000M		
		A type	B type	A type	B type	
Chuck	Chuck size	inch	24"	32"	24"	32"
Capacity	Swing over bed	mm	1,100	1,100	1,100	1,100
	Swing over cross-slide (with tailstock)	mm	795	795	795	795
	Max turning diameter	mm	1,000	1,000	1,000	1,000
	Max milling diameter	mm	-	-	827	827
Spindle	Max turning length	mm	955	955	955	955
	Spindle speed	rpm	1,800	800	1,800	800
Spindle	Spindle nose	ASA	A2-15	A2-15	A2-15	A2-15
	Draw tube ID	mm	-	-	-	-
	Spindle bore	mm	100	100	100	100
	Spindle motor (cont/max)	kW	37/55	37/55	37/55	37/55
Travels	X-axis stroke	mm	540	540	540	540
	Z-axis stroke	mm	955	955	955	955
	X-axis stroke	m/min	20	20	20	20
	Z-axis stroke	m/min	20	20	20	20
Turret	No of tool positions	ea	12	12	12 (BMT85)	12 (BMT85)
	OD tool size	mm	32	32	32	32
	Boring bar diameter	mm	80	80	80	80
	Indexing time	sec	0.30	0.30	0.30	0.30
	Rotary tool speed	rpm	-	-	3,000	3,000
	Rotary tool motor (cont/max)	kW	-	-	5.5/11	5.5/11
Tailstock	Quill diameter	mm	-	-	-	-
	Quill stroke	mm	-	-	-	-
	Quill taper	MT	-	-	-	-
Machine	Size (with SIDE chip conveyor) L×W×H	mm	2,510(3,744) × 2,329 × 3,619		2,510(3,744) × 2,329 × 3,619	
	Size (with REAR chip conveyor) L×W×H	mm	2,510 × 2,329(4,263) × 3,619		2,510 × 2,329(4,263) × 3,619	
	Weight	kg	17,000	17,000	17,200	17,200
	Coolant tank capacity	Liter	350		350	
Electric power supply	kVA/V	75/220	75/220	80/220	80/220	
Controller	FANUC					

* Design and specifications are subject to change without notice.

NC Specification / FANUC

● : STD ○ : Optional X : N/A

Functions		F0i-TF+	Functions		F0i-TF+
Controlled axis	Controlled axes	X, Z, C	Absolute / incremental command	G90/G91	
	Max simultaneously controlled axes	4	Repeating canned cycle	●	
	Least input increment	0.001mm / 0.0001"	Repeating canned cycle 2	●	
	Built-in stroke limit	Soft overtravel 1, 2, 3, 4	Canned cycles	●	
Operation functions	Machine lock	●	Drilling canned cycle	●	
	Manual handle feed	X1, X10, X100	Decimal point input	●	
	Dry run	●	Inch / metric conversion	G20 / G21	
	Single block	●	Program restart	●	
	Feed per minute	G94	Sub program call	●	
	Feed per revolution	G95	Max programmable value	±99999.999mm/±9999.9999"	
	DNC operation	Ethernet, CF card	M function	3 digit	
Interpolation functions	Thread cutting pause	○	Custom macro	●	
	Linear interpolation	G01	Addition of custom macro common variables	#100~#199, #500~#999 (#98000 ~ #98499)	
	Circular interpolation	G02, G03	Direct drawing dimension programming	●	
	Dwell	G04	Programmable data input	G10	
	Cylindrical interpolation	G70.1	Tape code	ISO / EIA	
	Skip	G31	Optional block skip	●	
	Nano smoothing	X	Workpiece coordinate system	G52 ~ G59	
	Polar coordinate interpolation	●	Addition of workpiece coordinate system	X	
	Reference position (zero) return	G28	Interface function	Embedded ethernet	●
	Reference position (zero) return check	G27		Fast ethernet	○
	2nd, 3rd, 4th reference point return	G30	Setting and display	Alarm and operator history display	●
	Variable lead thread cutting	●		Run hour and parts count display	●
Thread repair	●	Loadmeter display		●	
Feed function	Rapid traverse override	F0, 25%, 50%, 100%		Self diagnosis function	●
	Feedrate override	0~150%		Extended part program editing	●
	Jog override	●		Machining condition selection function	○
	AI contour control I	○ (40 block)		Machining quality level adjustment	X
	AI contour control II	○ (200 block)		Display screen	15" color LCD
	Look ahead block expansion (F0i)	X	Multi-language display	25 language	
Spindle function	High-speed processing	X	Data input/output	Fast data server	○
	Look ahead block expansion	X		RS232C interface	●
	Smooth tolerance control	X		Memory card input / output	●
Tool functions	Spindle orientation	●	USB memory input / output	●	
	Rigid tapping	M29	Editing operation	Part program storage size	2Mbyte
	Spindle override	50 ~ 150%		Number of registered programs	1,000EA
	Arbitrary speed threading	○		Manual guide 0i	X
	Tool number command	T4-Digt Tool number		Manual guide i	●
	Tool nose radius compensation	G40 ~ G42			
	Tool offset pairs	128-pairs			
Tool geometry / wear offset	●				
Tool length compensation	X				
Tool life management	●				
Tool path graphic display	●				